

*Delivers centimeter level accuracy within seconds based on U-blox triple-band L1/L2 **ZED-F9P** GNSS RTK module.
Onboard **RM3100** magnetometer.*

Datasheet - In Production



Description

The Siderion **Sirius F9P** is an affordable compact and high precision L1/L2 GNSS RTK (Real Time Kinematic) device with an onboard GNSS active antenna.

Based on the last generation of GNSS U-blox ZED-F9P modules, the Sirius F9P offers reliable and fast convergence time to provide centimeter accuracy within seconds.

The device allows concurrent reception of GPS / GLONASS / BeiDou & Galileo signals to improve signal availability.

The Sirius F9P embeds an active L1/L2 GNSS antenna and a professional grade RM3100 magnetometer.

The JST-GH connectors make them perfect to be connected to a Pixhawk3Pro or any other autopilot.

The Sirius F9P GNSS RTK is guaranteed to operate over a temperature range of -40°C to +70°C.

Features

- 5V - 150mA power supply
- LEDs status: PPS/Power/RTK
- Timepulse & External Interrupt
- USB-C/I²C/UART digital interfaces
- Onboard PNI RM3100 compass
- Onboard L1/L2 active antenna

Applications

- Drones
- RTK Base
- Ground vehicles
- Precise navigation

Table 1. Device summary

Order ref code	Temperature [°C]	Product size [mm]	Weight [g]
SID-GNSS-RTK-SIRIUS_F9P	-40 to +70	74.0 x 74.0 x 22.0	100

Contents

1. Block diagram and pin description	3
1.1 Block diagram	3
1.2 LED description	3
1.3 Pin description	4
2. Absolute maximum ratings	5
3. Specifications	6
3.1 Ublox ZED-F9P specifications	6
3.2 PNI RM3100 specifications	8
3.3 Embedded L1/L2 GNSS antenna specifications	10
4. Applications	11
5. Communication interfaces	12
5.1 UART Interface	12
5.2 Slave I2C interface	13
5.3 USB interface	13
6. Mechanical drawings	14
7. Revision history	14
8. Appendix	15

1. Block diagram and pin description

1.1 Block diagram

Figure 1. Sirius F9P block diagram & connectivity (top view)

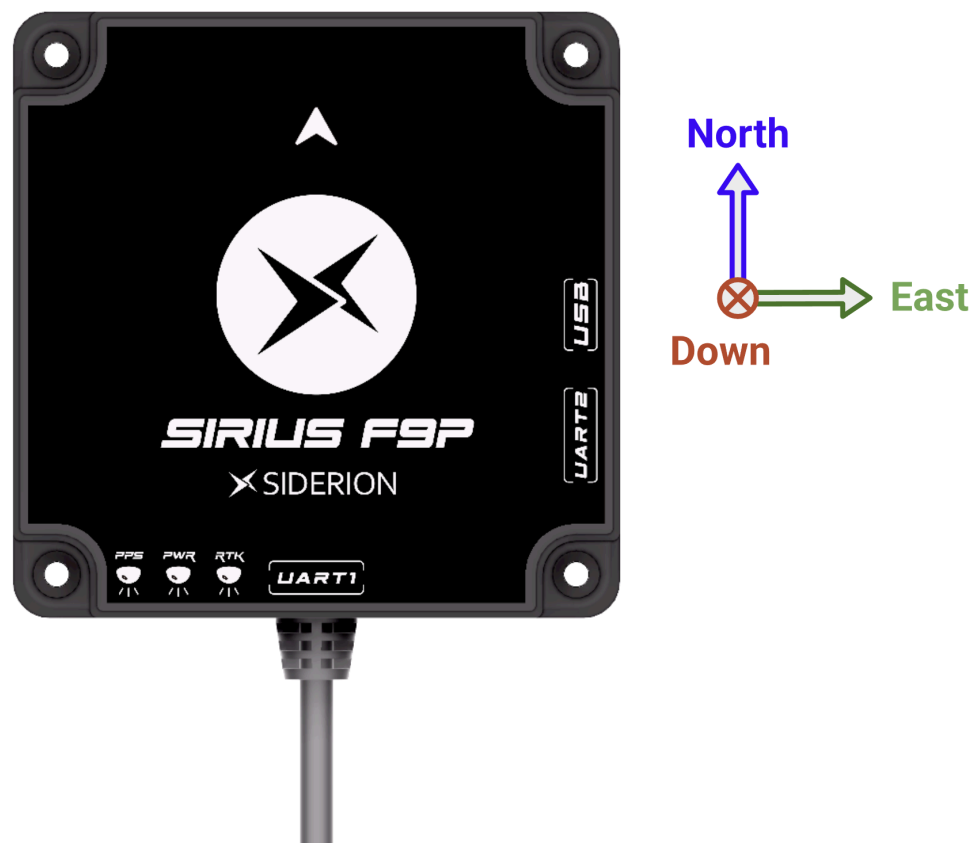

1.2 LED description

Table 2. Sirius F9P LED sequence status

LED name	Color	Light sequence	Comment
Timepulse	Green		Blinking LED at the defined PPS rate
Power	Blue		Solid blue LED when powered ON
RTK Status	Green		3D fix mode / No RTK fix
			RTK fix but no FIXED RTK fix
			FIXED RTK fix

1.3 Pin description

Figure 2. Sirius F9P pinout (top view)

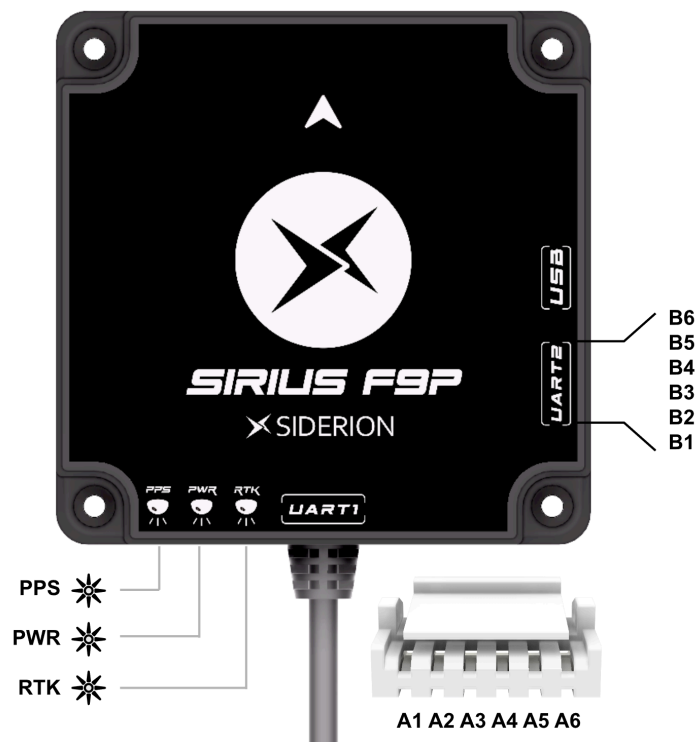

Table 3. Pinout configuration

	Pin	Name	Type	Function
GPS	A1	GND	P	Ground reference
	A2	I2C SDA	I/O	I2C data
	A3	I2C SCL	I	I2C clock
	A4	UART1 TX	O	UART1 transmit
	A5	UART1 RX	I	UART1 receive
	A6	5V IN	P	5V input
UART	B1	5V IN	P	5V input
	B2	UART2 TX	O	UART2 transmit NMEA/RTCM data
	B3	UART2 RX	I	UART2 receive NMEA/RTCM data
	B4	EXTINT	O	External interrupt
	B5	TIMEPULSE	O	PPS output
	B6	GND	P	Ground reference

P : Power / I : Input / O : Output

2. Absolute maximum ratings

Stresses above those listed as “absolute maximum ratings” may cause permanent damage to the device. This is a stress rating only and functional operation of the device under these conditions is not implied. Exposure to maximum rating conditions for extended periods may affect device reliability.

Table 4. Sirius F9P absolute maximum ratings

Symbol	Parameter	Maximum value	Units
Vusb	USB supply voltage	-0.3 to +6	V
Vdd	Internal supply voltage	-0.5 to +3.6	V
Vdd_IO	I/O pins supply voltage	-0.5 to Vdd+0.1	V
Icc_RF	RF output current	300	mA
Prfin	Input power at RF_IN	10	dBm
W	Product weight	100	g
TOP	Operating temperature	-40 to +70	°C
TSTG	Storage temperature	-40 to +80	°C



This device is sensitive to electrostatic discharge (ESD), improper handling can cause permanent damage to the part.

3. Specifications

3.1 Ublox ZED-F9P specifications

Table 5. ZED-F9P mechanical and electrical specifications

Symbol	Parameter	Test conditions	Min.	Typ.	Max.	Units
Vusb	USB supply voltage		4.5	5.0	5.5	V
Vdd	Internal supply voltage			3.3		V
Vdd_IO	Supply voltage for I/O			3.3		V
Idd	Current consumption	w/o active antenna		50		mA
		w/ active antenna		130		mA
Vdd_RF	Output RF voltage			Vdd-0.1		V
Idd_RF	Output RF current			50		mA
Vil	IO pin low lvl input volt		0		0.8	V
Vih	IO pin high level input voltage		2		Vdd +0.3	V
Vol	IO pin low level output voltage	Iol = 1mA			0.4	V
Voh	IO pin high level output voltage	Ioh = 1mA	Vdd-0.4			V
Top	Operating temperature		-40		+70	°C
I2Cadd	Default 7bit I ² C address	0b0100010 (0x42)				

Table 6. ZED-F9P general performance

Parameter	Specifications	Value
Receiver type	Multi-band GNSS high precision	
Accuracy of Timepulse	RMS	30 ns
Frequency of Timepulse		0.25 Hz to 10 MHz
Operational limits	Dynamics Altitude Velocity	< 4g 50,000 m 500 m/s
Velocity accuracy		0.03 m/s

Table 7. ZED-F9P performance in different GNSS mode

GNSS	Parameter	GPS+GLO+GAL +BDS	GPS+GLO	GPS+BDS	GPS
Acquisition	Cold start	24 s	26 s	28 s	29 s
	Hot start	2 s	2 s	2 s	2 s
	Aided start	2 s	2 s	2 s	2 s
Update rate	RTK	8 Hz	15 Hz	15 Hz	20 Hz
	PVT	10 Hz	25 Hz	25 Hz	25 Hz
	RAW	20 Hz	25 Hz	25 Hz	25 Hz
Convergence time	RTK	< 10 s	< 10 s	< 10 s	< 30 s
Horizontal pos. accuracy	PVT	1.5 m CEP	1.5 m CEP	1.5 m CEP	1.5 m CEP
	RTK	0.01 m + 1ppm CEP	0.01 m + 1ppm CEP	0.01 m + 1ppm CEP	0.01 m + 1ppm CEP
Vertical pos. accuracy	RTK	0.01 m + 1ppm CEP	0.01 m + 1ppm CEP	0.01 m + 1ppm CEP	0.01 m + 1ppm CEP
Sensitivity	Tracking & Nav.	-167 dBm			
	Reacquisition	-160 dBm			
	Cold start	-148 dBm			
	Hot start	-157 dBm			

Table 8. ZED-F9P moving-base performance in different GNSS mode

GNSS	Parameter	GPS+GLO+GAL +BDS	GPS+GLO	GPS+BDS	GPS
Update rate		5 Hz	8 Hz	8 Hz	10 Hz
Heading accuracy		0.4 deg	0.4 deg	0.4 deg	0.4 deg

3.2 PNI RM3100 specifications

Table 9. RM3100 electrical specifications

Symbol	Parameter	Test conditions	Min.	Typ.	Max.	Units
Vdd	Internal supply voltage		2.0	3.0	3.6	V
Vdd_IO	Supply voltage for I/O		2.0	3.0	3.6	V
Vdd_Ripple	Vdd ripple voltage				0.05	Vpp
Idd	Current consumption				1	mA
Vil	IO pin low level input voltage		0		0.3* Vdd	V
Vih	IO pin high level input voltage		0.7* Vdd		Vdd	V
Iidle	Idle Mode Current				1	μA
Ileak	Leakage Current @ DVDD pin (AVDD=AVSS=DVSS=0V, DVDD=3.6V)				100	nA
Top	Operating temperature		-20		+85	°C
I2Cadd	7bit I2C address	0b0100000				

Table 10. RM3100 Geomagnetic Sensor Performance

Parameter	Cycle counts			Units
	50	100	200	
Field Measurement Range	-800 to +800			μT
Gain	20	38	75	LSB/ μT
Sensitivity	50	26	13	nT
Noise	30	20	15	nT
Noise Density @ Max. Single-Axis Sample Rate	1.2			nT/ $\sqrt{\text{Hz}}$
Repeatability over $\pm 200 \mu\text{T}$	15	8	8	nT
Hysteresis over $\pm 200 \mu\text{T}$	15			nT
Linearity over $\pm 200 \mu\text{T}$	0.5			%
Maximum Single-Axis Sample Rate (divide by 3 for max. 3-axis sample rate)	1600	850	440	Hz
Single-Axis Average Current @ 24 Hz Sample Rate (equivalent to 3-axis @ 8 Hz)	70	135	260	μA
Bias Resistor, Rb	121			Ω
Ext. Timing Resistor for Clock, REXT	33			K Ω
Circuit Oscillation Frequency	180			kHz

3.3 Embedded L1/L2 GNSS antenna specifications

Table 11. Internal multi-band antenna mechanical and electrical specifications

Symbol	Parameter	Value
ANTENNA		
Arch	Antenna architecture	Quadrifilar helix
Gband	GNSS signal bands	GPS: L1/L2 GLONASS: G1/G2 BDS: B1/B2 Galileo: E1/E2/E5
Gpp	Peak gain	≥2.0 dBi
Pol	Polarization	RHCP
VSWR	V.S.W.R.	≤2.0
Acov	Azimuth coverage	360°
Z	Impedance	50Ω
LNA		
Glna	LNA gain	28±2.0dB (Typ. @25°C)
Idd	Operating current	≤50mA
Nfig	Nois Figure	<1.5dB
Pbf	Pass band fluctuation	±1.5dB
MECHANICAL & ENVIRONMENTAL		
IP	IP rating	IP66
Top	Operating temperature	-40°C to +85°C
Size	Antenna dimensions	60.0 x 60.0 x 20mm

4. Applications

5. Communication interfaces

There are several communication interfaces, including UART, I2C, and USB. All inputs have internal pull-up resistors in normal operation and can be left open if not in use. All the PIOs are supplied by VCC, therefore all the voltage levels of the PIO pins are related to Vdd supply voltage.

5.1 UART Interface

There are two UART interfaces: UART1 and UART2. UART1 and UART2 operate up to and including a speed of 1 Mbaud. No hardware flow control on UART1 and UART2 is supported.

Figure 3. UART chronogram specifications

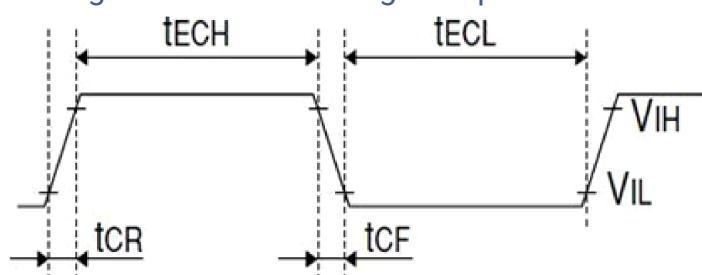

Table 12. ZED-F9P serial UART timing specifications

Symbol	Parameter	Min.	Max.	Unit
Vil	LOW-LEVEL input voltage	0	0.2xVdd	V
Vih	HIGH-LEVEL input voltage	0.7xVdd	Vdd+0.3	V
tECH	HIGH period of external data input	0	0.4	μs
tECL	LOW period of external data input	TBA	TBA	μs
Ru	Baudrate	9600	921600	bps
tCR	Rise time of data		5	ns
tCF	Fall time of data		5	ns

5.2 Slave I2C interface

An I2C compliant interface is available for communication with an external host CPU. The interface can be operated in slave mode only. It is fully compatible with Fast-Mode of the I2C industry standard. Since the maximum SCL clock frequency is 400 kHz, the maximum bit rate is 400 kbit/s. The interface stretches the clock when slowed down while serving interrupts, therefore the real bit rates may be slightly lower.

Figure 4. I2C chronogram specifications

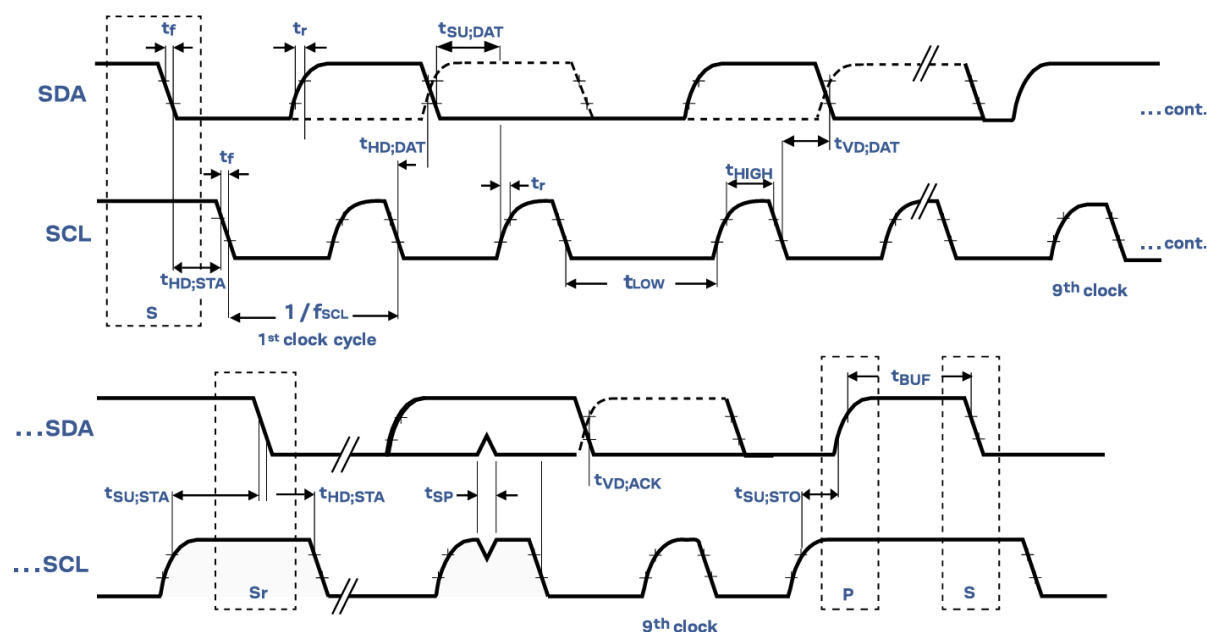

Table 13. Sirius F9P I2C timing specifications

Symbol	Parameter	Min	Max	Unit
Vil	LOW-LEVEL input voltage	Vss-0.3	0.3xVdd	V
Vih	HIGH-LEVEL input voltage	0.7xVdd	Vdd+0.3	V
Vol	LOW-LEVEL output voltage		0.4	V
Voh	HIGH-LEVEL output voltage	Vdd-0.4		V
Fscl	SCL clock frequency	0	400	KHz

5.3 USB interface

A USB type C interface, which is compatible with USB version 2.0 FS (Full Speed, 12 Mbit/s), can be used for communication as an alternative to the UART.

6. Mechanical drawings

Figure 5. Sirius F9P v2.1 mechanical drawings

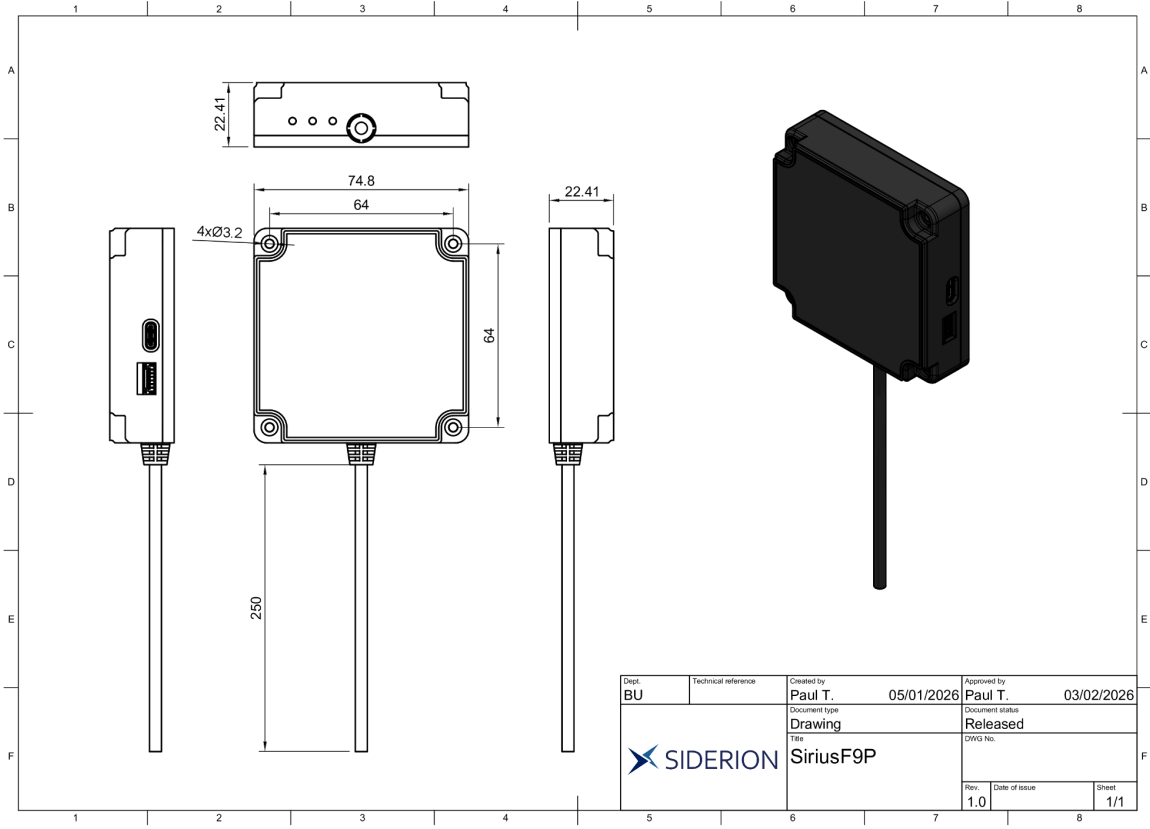

7. Revision history

Table 14. Document revision history

Date	Revision	Changes
16-Feb-2026	1.0	SiderionDoc_SiriusF9P / Initial release

8. Appendix

U-blox ZED-F9P datasheet : [ZED-F9P-05B Data sheet](#)

U-blox ZED-F9P integration manual : [ZED-F9P Integration manual](#)

U-blox ZED-F9P interface description : [u-blox F9 HPG 1.51 Interface description](#)

Siderion user's guide:

Siderion tutorials:

IMPORTANT NOTICE – PLEASE READ CAREFULLY

Siderion reserves the right to make changes, corrections, enhancements, modifications, and improvements to Siderion products and/or to this document at any time without notice. Purchasers should obtain the latest relevant information on Siderion products before placing orders. Siderion products are sold pursuant to Siderion's terms and conditions of sale in place at the time of order acknowledgement.

Purchasers are solely responsible for the choice, selection, and use of Siderion products and Siderion assumes no liability for application assistance or the design of Purchasers' products.

No license, express or implied, to any intellectual property right is granted by Siderion herein.

Resale of Siderion products with provisions different from the information set forth herein shall void any warranty granted by Siderion for such product.

Information in this document supersedes and replaces information previously supplied in any prior versions of this document.

2026 Siderion – All rights reserved

