

High precision, multi-band L1/L2/L5 RHCP helical Active GNSS Antenna for demanding environments.

Datasheet - In Production



Description

The Siderion **SA275** is a high-performance helical multi-band active GNSS antenna designed for precision navigation and positioning applications.

Leveraging multi-arm, multi-feed point technology, it supports L1, L2 & L5 signal reception across BeiDou, GPS, GLONASS and Galileo satellite systems

Engineered with a built-in multi-stage filter and low-noise amplifier, the SA275 delivers superior out-of-band suppression and robust anti-interference capabilities, ensuring reliable operation even in harsh electromagnetic environments.

Its IP67-rated enclosure ensures dustproof and waterproof protection, and with an operational temperature range of -40°C to +85°C, the SA275 is built to deliver reliable performance in the most demanding environments.

Features

- 3V to 6V - 45mA power supply
- Sealing rubber ring (IP67)
- Low noise, High gain
- Excellent out-of-the band rejection
- Small and lightweight
- Gold plated SMA-J connector

Applications

- Drones
- RTK Base or Rover
- Ground vehicles
- Precise navigation
- Portable devices

Table 1. Device summary

Order ref code	Temperature [°C]	Product size [mm]	Weight [g]
SID-GNSS-ANT-SA275	-40 to +85	54.0 x 27.8	16

Contents

1. Specifications	3
2. Mechanical drawings	4
3. Revision history	5

1. Specifications

Table 1. SA275 mechanical and electrical specifications

Symbol	Parameter	Value
ANTENNA		
Arch	Antenna architecture	Quadrifilar helix
Gband	GNSS signal bands	GPS: L1/L2/L5 GLONASS: G1/G2 BDS: B1/B2/B3 Galileo: E1/E5/E6
Gpp	Peak gain	≥2.0 dBi
Pol	Polarization	RHCP
Arat	Axial ratio @ zenith	≤3.0dB
Acov	Azimuth coverage	360°
Z	Impedance	50Ω
LNA		
Vdd	Operating voltage	3.0V ~ 6.0V
Idd	Operating current	≤45mA
Fran	Frequency Range	1164MHz ~ 1278MHz 1525MHz ~ 1615MHz
Glna	LNA gain	32±2.0dB (Typ. @25°C)
MECHANICAL & ENVIRONMENTAL		
IP	IP rating	IP67
Con	Connector	SMA-J
Wei	Weight	16g
Mat	Plastic material	ABS + PC
Top	Operating temperature	-40°C to +85°C
Size	Antenna dimensions	54.0 x 27.8mm

2. Mechanical drawings

Figure 1. SA275 v1.0 mechanical drawings

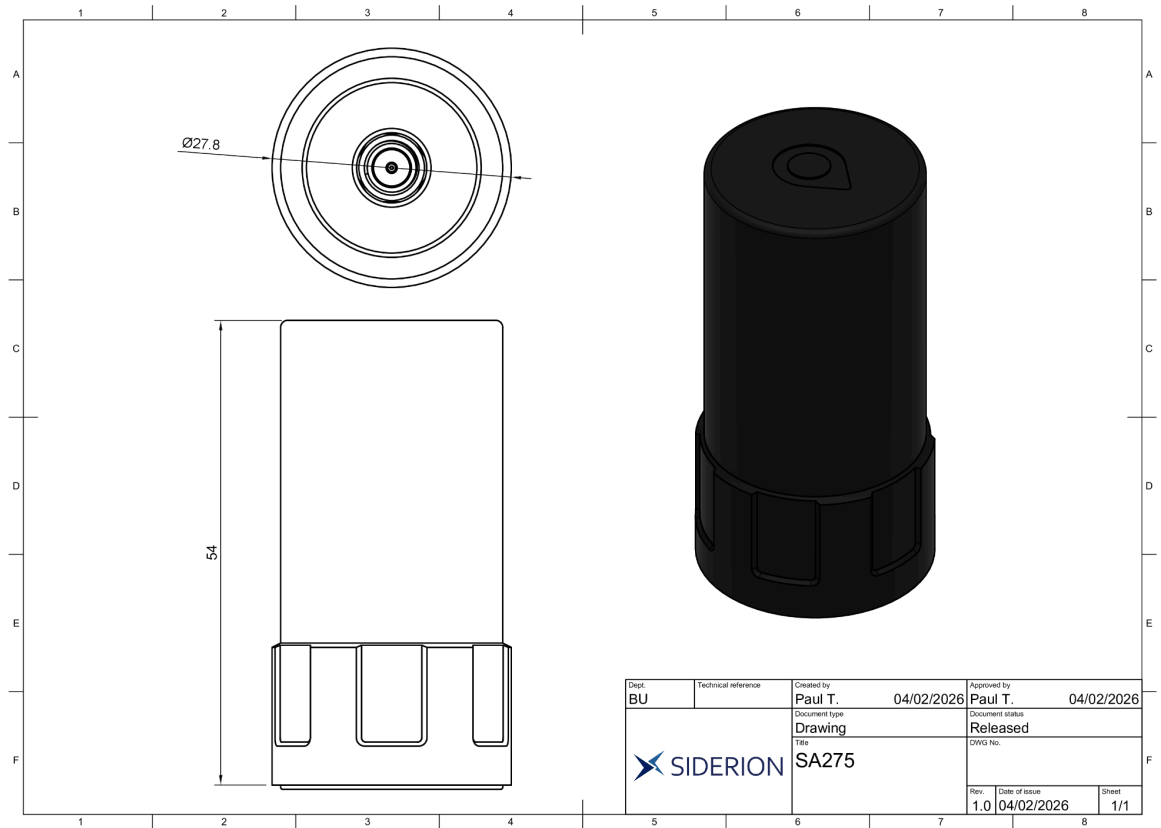

3. Revision history

Table 2. Document revision history

Date	Revision	Changes
13-Sep-2025	1.0	SiderionDoc_SA275 / Initial release

IMPORTANT NOTICE – PLEASE READ CAREFULLY

Siderion reserves the right to make changes, corrections, enhancements, modifications, and improvements to Siderion products and/or to this document at any time without notice. Purchasers should obtain the latest relevant information on Siderion products before placing orders. Siderion products are sold pursuant to Siderion's terms and conditions of sale in place at the time of order acknowledgement.

Purchasers are solely responsible for the choice, selection, and use of Siderion products and Siderion assumes no liability for application assistance or the design of Purchasers' products.

No license, express or implied, to any intellectual property right is granted by Siderion herein.

Resale of Siderion products with provisions different from the information set forth herein shall void any warranty granted by Siderion for such product.

Information in this document supersedes and replaces information previously supplied in any prior versions of this document.

2026 Siderion – All rights reserved

