

Delivers centimeter level accuracy within seconds based on U-blox ZED-F9P L1/L2 GNSS module.

Datasheet - In Production

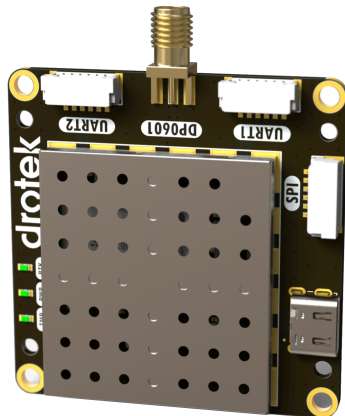

Description

The Siderion **DP0601** is an affordable compact and high precision L1/L2 GNSS RTK (Real Time Kinematic) device.

Based on the last generation of GNSS U-blox ZED-F9P modules, the DP0601 offers reliable and fast convergence time to provide centimeter accuracy within seconds.

The device allows concurrent reception of GPS / GLONASS / BeiDou & Galileo signals to improve signal availability.

The JST-GH connectors make them perfect to be connected to a Pixhawk3Pro or any other autopilot.

The DP0601 GNSS RTK is guaranteed to operate over a temperature range of -20°C to +70°C.

Features

- 5V - 100mA power supply
- LEDs status : Timepulse/Power/RTK
- Timepulse & External Interrupt
- USB-C/I²C/SPI/UART interfaces
- Gold plated SMA connector
- ESD protection diodes
- 3.3V Active antenna input

Applications

- Drones
- RTK Base
- Ground vehicles
- Precise navigation
- Automation of moving machinery

Table 1. Device summary

Order ref code	Temperature [°C]	Product size [mm]	Weight [g]
SID-GNSS-RTK-DP0601	-40 to +70	50.0 x 50.0 x 8.0	17

Contents

1. Block diagram and pin description	3
1.1 Block diagram	3
1.2 LED description	3
1.3 Pin description	4
2. Absolute maximum ratings	5
3. Specifications	6
4. Applications	8
4.1 Standalone Base/Rover configuration	8
4.2 NTRIP (Network Transport of RTCM via Internet Protocol) local configuration	8
4.3 NTRIP cellular configuration	9
4.4 Moving Base/Rover for distance & heading evaluation	9
5. Communication interfaces	10
5.1 UART Interface	10
5.2 SPI interface	11
5.3 Slave I2C interface	12
5.4 USB interface	12
6. Mechanical drawings	13
7. Revision history	15
8. Appendix	15

1. Block diagram and pin description

1.1 Block diagram

Figure 1. DP0601 block diagram & connectivity (top view)

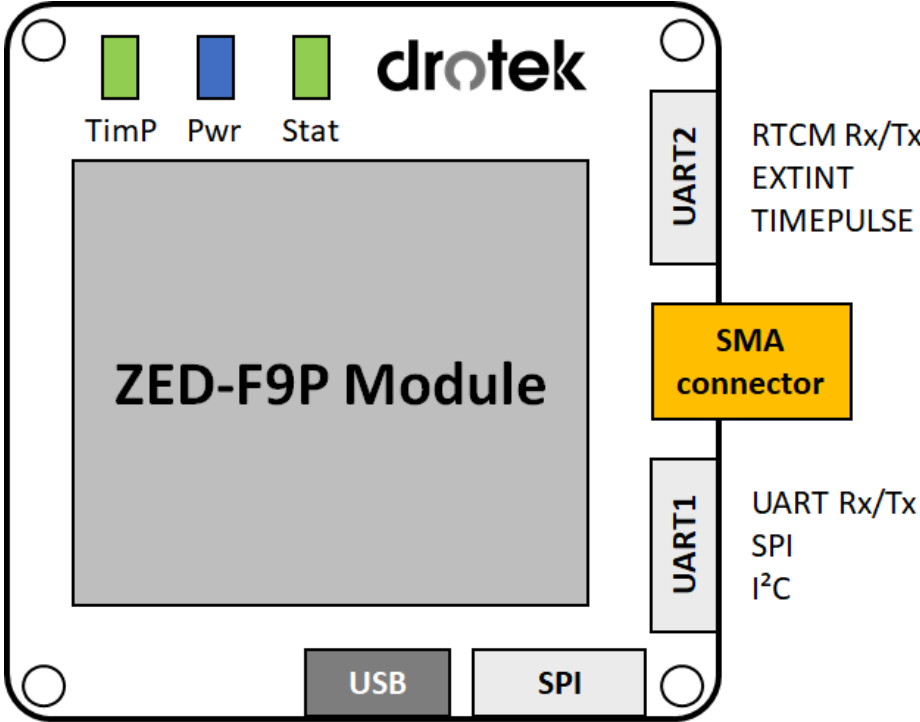

1.2 LED description

Table 2. DP0601 LED sequence status

LED name	Color	Light sequence	Comment
Timepulse	Green		Blinking LED at the defined PPS rate
Power	Blue		Solid blue LED when powered ON
RTK Status	Green		3D fix mode / No RTK fix
			RTK fix but no FIXED RTK fix
			FIXED RTK fix

1.3 Pin description

Figure 2. DP0601 pinout (top & side views)

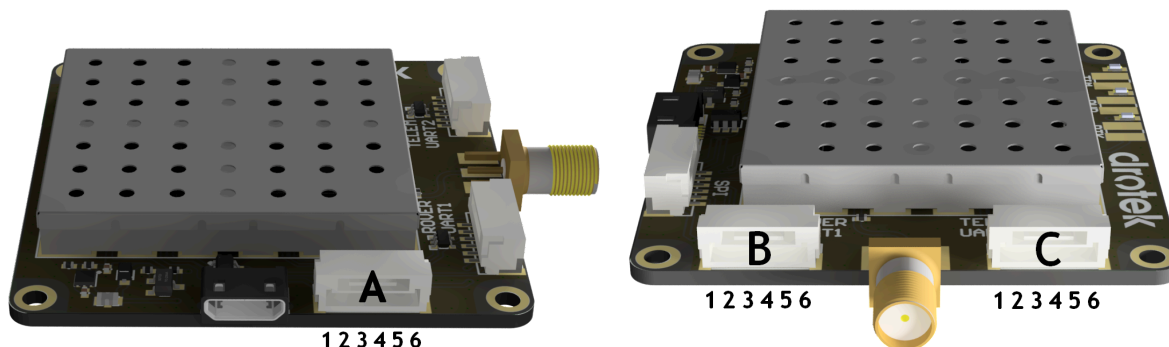

Table 3. Pinout configuration

	Pin	Name	Type	Function
SPI	A1	5V SPI	P	5V input to select SPI instead of UART1
	A2	SPI CLK	I	SPI clock input
	A3	SPI MISO	I	SPI Master Input Slave Output
	A4	SPI MOSI	O	SPI Master Output Slave Input
	A5	SPI CS	I	SPI chip select input
	A6	GND	P	Ground reference
UART 1	B1	5V IN	P	5V input
	B2	UART1 RXD / SPI MOSI	I	UART1 receive OR SPI MOSI
	B3	UART1 TXD / SPI MISO	O	UART1 transmit OR SPI MISO
	B4	I2C SCL / SPI SCLK	I	I2C clock OR SPI clock
	B5	I2C SDA / SPI CS	I/O	I2C data OR SPI chip select
	B6	GND	P	Ground reference
UART 2 / TELEM	C1	5V IN	P	5V input
	C2	UART2 TXD	O	UART2 transmit NMEA/RTCMdata
	C3	UART2 RXD	I	UART2 receive NMEA/RTCMdata
	C4	EXTINT	O	External interrupt
	C5	TIMEPULSE	O	External interrupt on Timepulse
	C6	GND	P	Ground reference

P : Power / I : Input / O : Output

2. Absolute maximum ratings

Stresses above those listed as “absolute maximum ratings” may cause permanent damage to the device. This is a stress rating only and functional operation of the device under these conditions is not implied. Exposure to maximum rating conditions for extended periods may affect device reliability.

Table 4. DP0601 absolute maximum ratings

Symbol	Parameter	Maximum value	Unit
Vusb	USB supply voltage	-0.3 to +6	V
Vdd	Internal supply voltage	-0.5 to +3.6	V
Vdd_IO	I/O pins supply voltage	-0.5 to Vdd+0.5	V
Icc_RF	RF output current	300	mA
Prfin	Input power at RF_IN	10	dBm
TOP	Operating temperature	-20 to +70	°C
TSTG	Storage temperature	-40 to +80	°C



This device is sensitive to electrostatic discharge (ESD), improper handling can cause permanent damage to the part.

3. Specifications

@Vdd = 5V, T = 25°C unless otherwise noted

Table 5. DP0601 mechanical and electrical specifications

Symbol	Parameter	Test conditions	Min.	Typ.	Max	Unit
Vusb	USB supply voltage		4.5	5.0	5.5	V
Vdd	Internal supply voltage			3.3		V
Vdd_IO	Supply voltage for I/O			3.3		V
Idd	Current consumption	w/o active antenna		50		mA
		w/ TW7972 antenna		130		mA
Vdd_RF	Output RF voltage			Vdd-0.1		V
Idd_RF	Output RF current			50		mA
Vil	IO pin low lvl input volt		0		0.8	V
Vih	IO pin high level input voltage		2		Vdd +0.3	V
Vol	IO pin low level output voltage	Iol = 2mA			0.4	V
Voh	IO pin high level output voltage	Ioh = 2mA	Vdd-0.4			V
Top	Operating temperature		-20		+70	°C
I2Cadd	Default 7bit I ² C address	0b0100010 (0x42)				

Table 6. DP0601 general performance

Parameter	Specifications	Value
Receiver type	Multi-band GNSS high precision	
Accuracy of Timepulse	RMS	30 ns
Frequency of Timepulse		0.25 Hz to 10 MHz
Operational limits	Dynamics Altitude Velocity	< 4g 50,000 m 500 m/s
Velocity accuracy		0.05 m/s

Table 7. DP0601 performance in different GNSS mode

GNSS	Parameter	GPS+GLO+GAL +BDS	GPS+GLO	GPS+BDS	GPS
Acquisition	Cold start	24 s	26 s	28 s	29 s
	Hot start	2 s	2 s	2 s	2 s
	Aided start	2 s	2 s	2 s	2 s
Update rate	RTK	8 Hz	15 Hz	15 Hz	20 Hz
	PVT	10 Hz	25 Hz	25 Hz	25 Hz
	RAW	20 Hz	25 Hz	25 Hz	25 Hz
Convergence time	RTK	< 10 s	< 10 s	< 10 s	< 30 s
Horizontal pos. accuracy	PVT	1.5 m CEP	1.5 m CEP	1.5 m CEP	1.5 m CEP
	RTK	0.01 m + 1ppm CEP	0.01 m + 1ppm CEP	0.01 m + 1ppm CEP	0.01 m + 1ppm CEP
Vertical pos. accuracy	RTK	0.01 m + 1ppm CEP	0.01 m + 1ppm CEP	0.01 m + 1ppm CEP	0.01 m + 1ppm CEP
Sensitivity	Tracking & Nav.	-167 dBm			
	Reacquisition	-160 dBm			
	Cold start	-148 dBm			
	Hot start	-157 dBm			

Table 8. DP0601 moving-base performance in different GNSS mode

GNSS	Parameter	GPS+GLO+GAL +BDS	GPS+GLO	GPS+BDS	GPS
Update rate		5 Hz	8 Hz	8 Hz	10 Hz
Heading accuracy		0.4 deg	0.4 deg	0.4 deg	0.4 deg

4. Applications

4.1 Standalone Base/Rover configuration

Figure 3. DP0601 connected to a Siderion telemetry kit + a L1/L2 Tallysman antenna

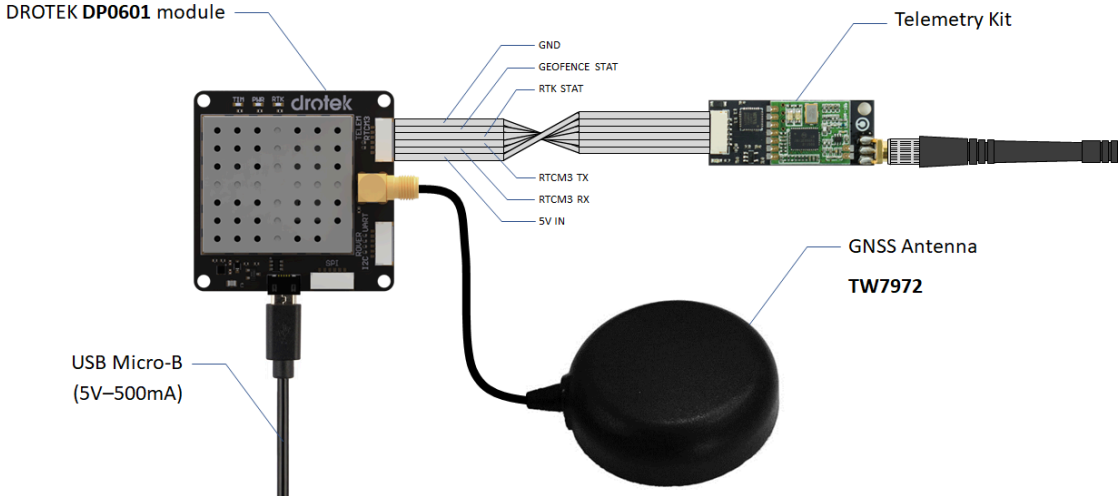

4.2 NTRIP (Network Transport of RTCM via Internet Protocol) local configuration

Figure 4. Two DP0601 connected to each other using NTRIP + local router

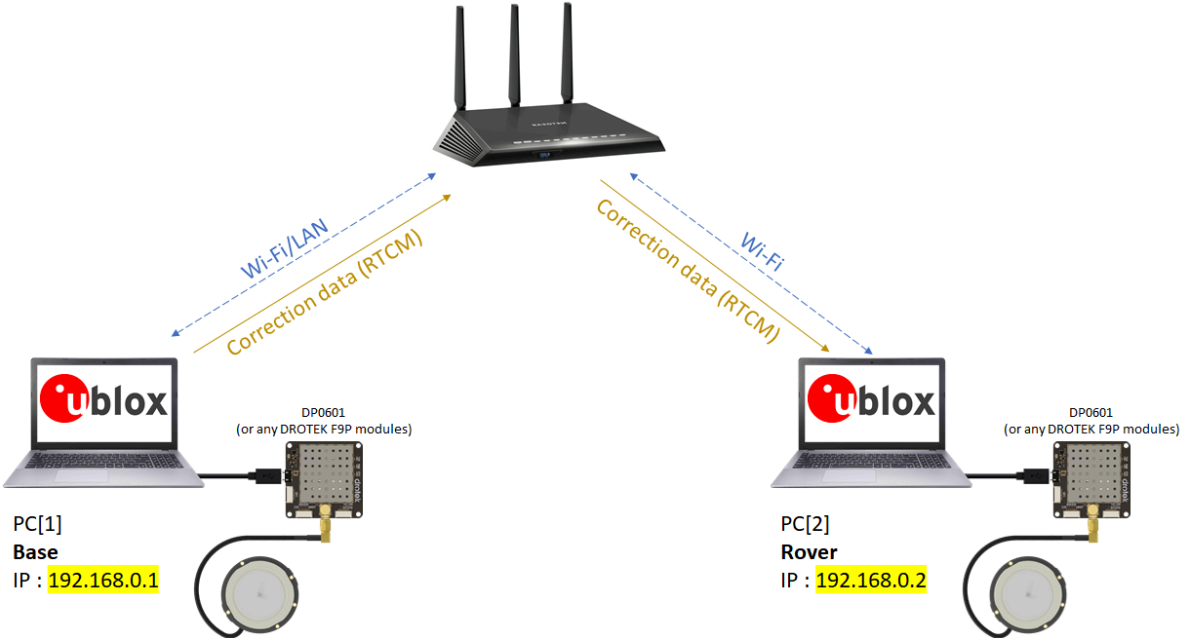

4.3 NTRIP cellular configuration

Figure 5. DP0601 linked to a on-field PC running u-center and connected to a 4G/LTE cellphone to receive RTCM data from distant servers

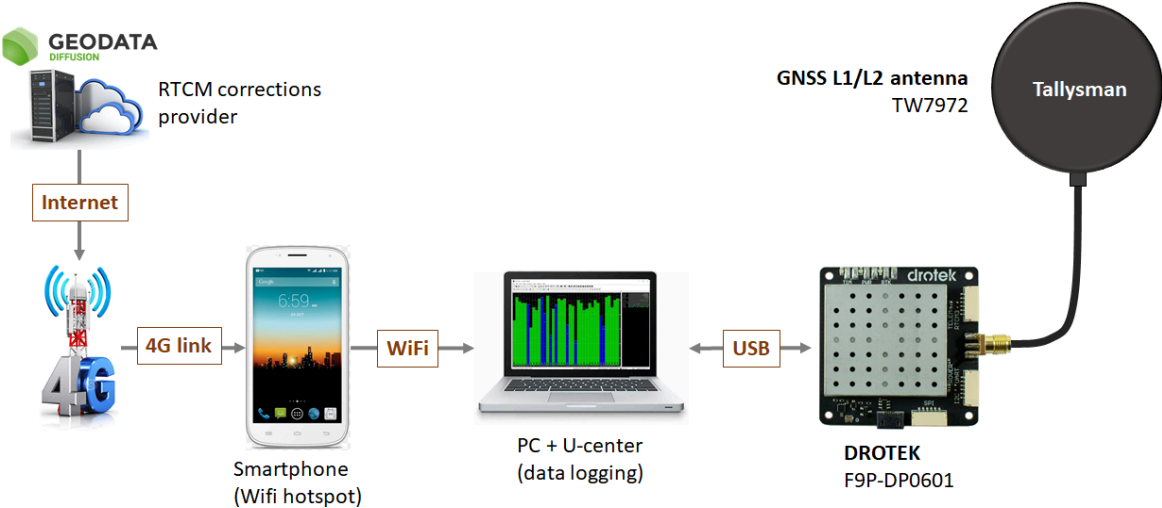

4.4 Moving Base/Rover for distance & heading evaluation

Figure 6. Two DP0601 used in a moving base configuration

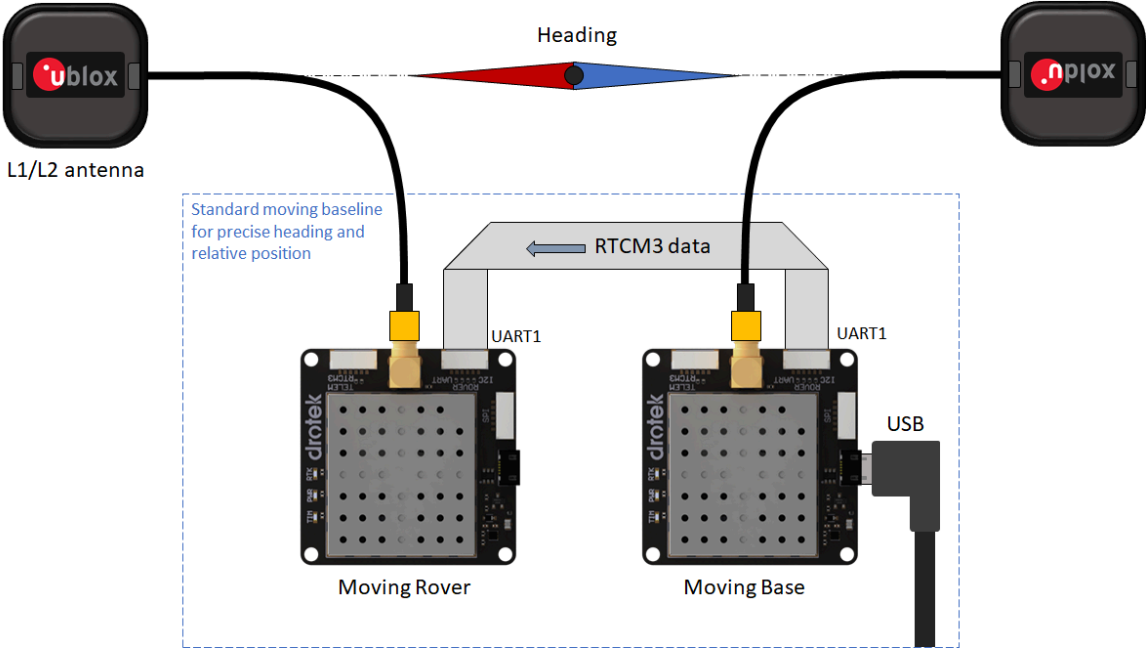

5. Communication interfaces

There are several communications interfaces including UART, SPI, I2C and USB. All the inputs have internal pull-up resistors in normal operation and can be left open if not used. All the PIOs are supplied by VCC, therefore all the voltage levels of the PIO pins are related to Vdd supply voltage.

5.1 UART Interface

There are two UART interfaces: UART1 and UART2. UART1 and UART2 operate up to and including a speed of 921600 baud. No hardware flow control on UART1 and UART2 is supported. UART1 is enabled by default if there is no 5V input voltage on pin A1 (5V SPI).

Figure 7. UART chronogram specifications

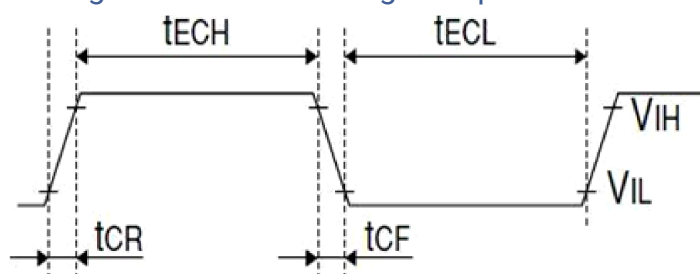

Table 9. DP0601 serial UART timing specifications

Symbol	Parameter	Min.	Max.	Unit
Vil	LOW-LEVEL input voltage	0	0.2xVdd	V
Vih	HIGH-LEVEL input voltage	0.7xVdd	Vdd+0.3	V
tECH	HIGH period of external data input	0	0.4	μs
tECL	LOW period of external data input	TBA	TBA	μs
Ru	Baudrate	9600	921600	bps
tCR	Rise time of data		5	ns
tCF	Fall time of data		5	ns

5.2 SPI interface

The DP0601 has an SPI slave interface that can be selected by supplying a 5V voltage on pin A1 (5V SPI). The SPI slave interface is shared with UART1. The SPI pins available are: SPI_MISO (TXD), SPI_MOSI (RXD), SPI_CS_N, SPI_CLK. The SPI interface is designed to allow communication to a host CPU. The interface can be operated in slave mode only. Note that SPI is not available in the default configuration because its pins are shared with the UART and I2C interfaces. The maximum transfer rate using SPI is 125 kB/s and the maximum SPI clock frequency is 5.5 MHz.

This section provides SPI timing values for the ZED-F9P slave operation. The following tables present timing values under different capacitive loading conditions. Default SPI configuration is CPOL = 0 and CPHA = 0.

Figure 8. SPI chronogram specifications

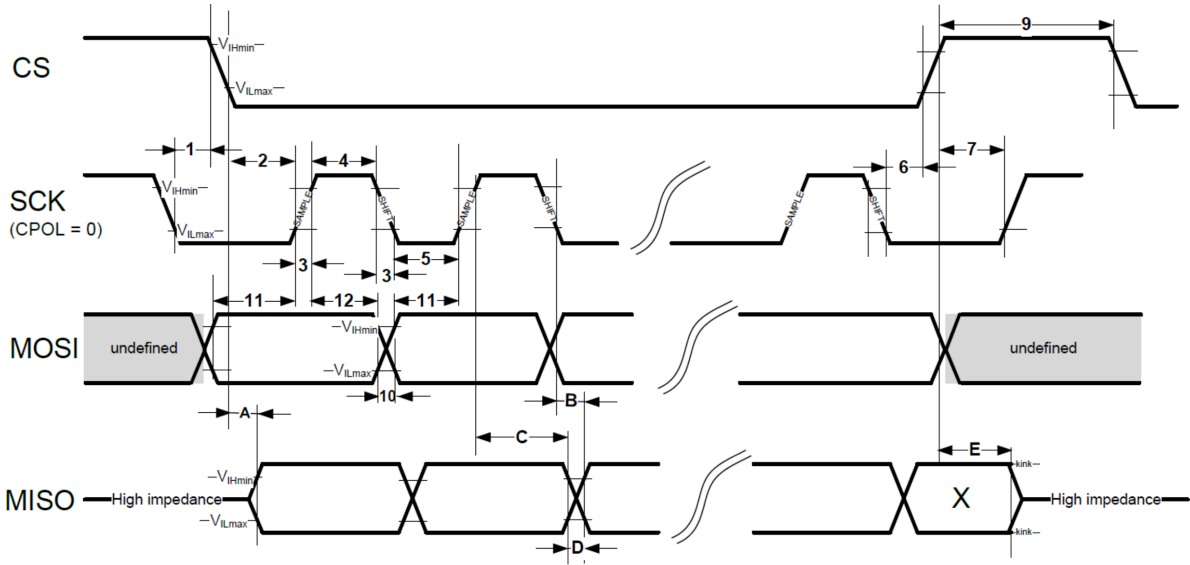

Table 10. DP0601 SPI timing specifications

Timing value @ 20pF load	Min [ns]	Max [ns]
"A" - MISO data valid time (CS)	19	52
"B" - MISO data valid time (SCK) weak driver mode	25	51
"C" - MISO data hold time	117	137
"D" - MISO rise/fall time, weak driver mode	6	16
"E" - MISO data disable lag time	20	32

5.3 Slave I2C interface

An I2C compliant interface is available for communication with an external host CPU. The interface can be operated in slave mode only. It is fully compatible with Fast-Mode of the I2C industry standard. Since the maximum SCL clock frequency is 400 kHz, the maximum bit rate is 400 kbit/s. The interface stretches the clock when slowed down while serving interrupts, therefore the real bit rates may be slightly lower.

Note : The I2C interface is only available with the UART default mode. If the SPI interface is selected by supplying a 5V onto the A1 pin (5V SPI), the I2C is not available.

Figure 9. I2C chronogram specifications

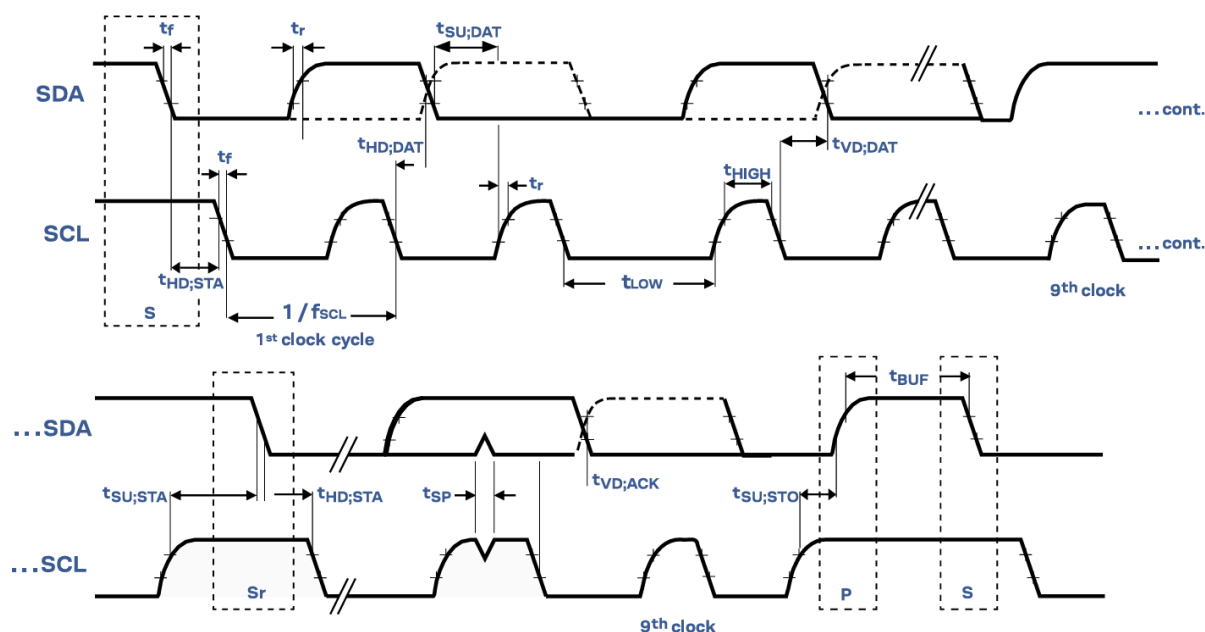

Table 11. DP0601 I2C timing specifications

Symbol	Parameter	Min	Max	Unit
Vil	LOW-LEVEL input voltage	Vss-0.3	0.3xVdd	V
Vih	HIGH-LEVEL input voltage	0.7xVdd	Vdd+0.3	V
Vol	LOW-LEVEL output voltage		0.4	V
Voh	HIGH-LEVEL output voltage	Vdd-0.4		V
Fscl	SCL clock frequency	0	400	KHz

5.4 USB interface

A USB interface, which is compatible with USB version 2.0 FS (Full Speed, 12 Mbit/s), can be used for communication as an alternative to the UART.

6. Mechanical drawings

Figure 10. DP0601 v1.2.1 mechanical drawings

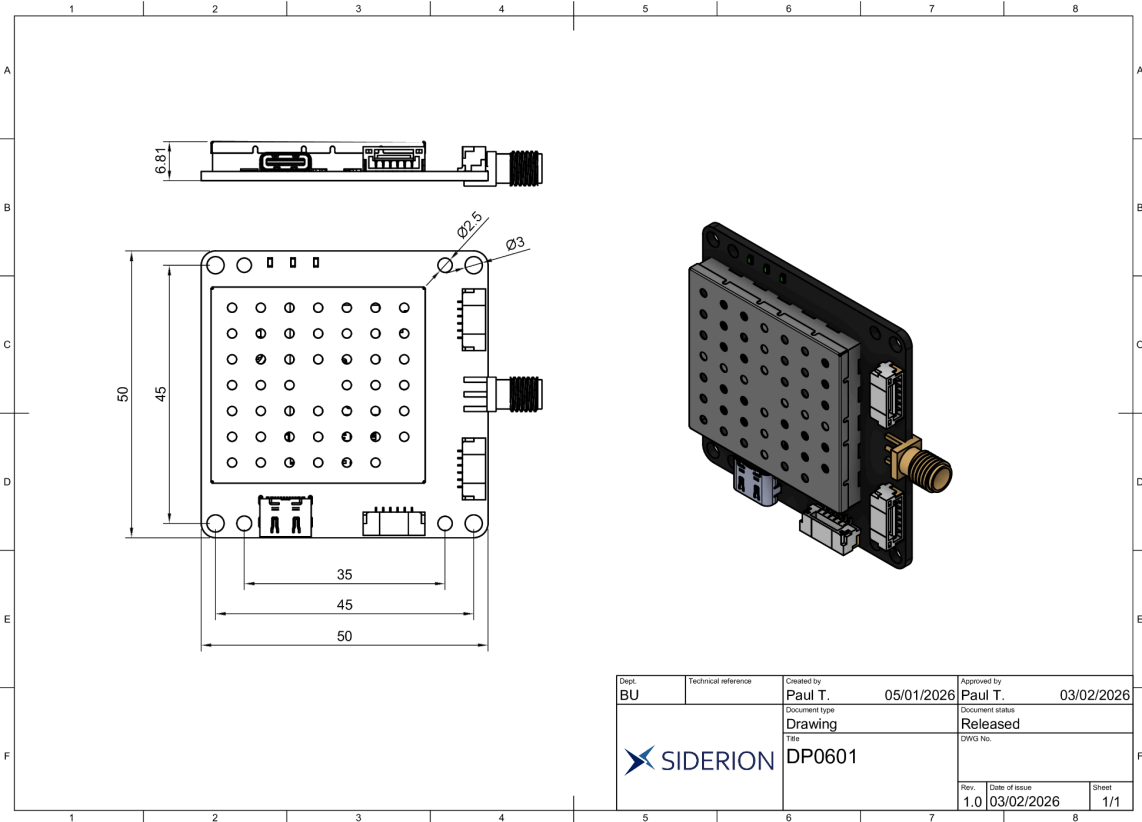
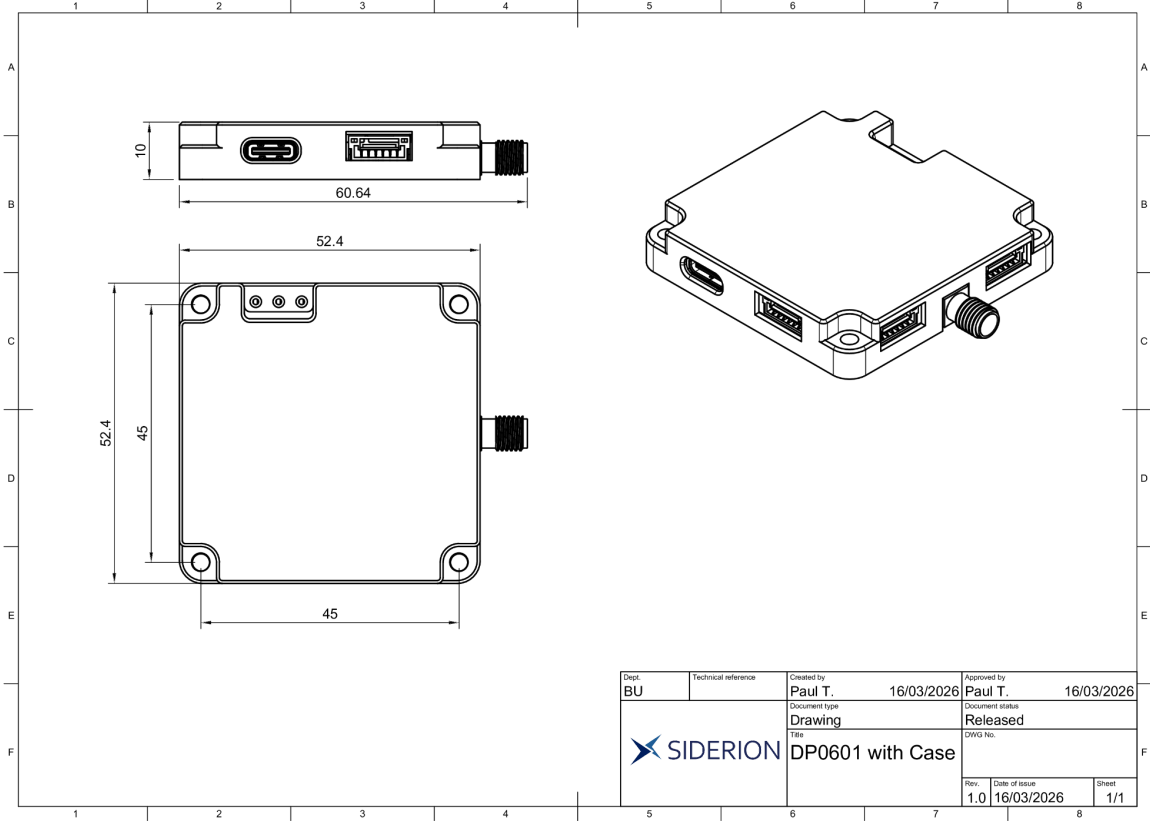

Figure 11. DP0601 v1.2.1 with case mechanical drawings



Dept. BU	Technical reference	Created by Paul T.	16/03/2026	Approved by Paul T.	16/03/2026
		Document type Drawing	Document status Released		
		Title DP0601 with Case		DWG No.	
		Rev. 1.0	Date of issue 16/03/2026	Sheet 1/1	

7. Revision history

Table 12. Document revision history

Date	Revision	Changes
22-Oct-2019	1.0	SiderionDoc_0891B08A / Initial release
14-09-2020	1.1	MISO / MOSI pins swapped (page 4)
15-09-2025	1.2	Updated
16-03-2026	1.3	Optional enclosure mechanical drawing added

8. Appendix

U-blox ZED-F9P datasheet : [ZED-F9P-05B Data sheet](#)

U-blox ZED-F9P integration manual : [ZED-F9P Integration manual](#)

U-blox ZED-F9P interface description : [u-blox F9 HPG 1.51 Interface description](#)

Siderion user's guide :

Siderion tutorials :

IMPORTANT NOTICE – PLEASE READ CAREFULLY

Siderion reserves the right to make changes, corrections, enhancements, modifications, and improvements to Siderion products and/or to this document at any time without notice. Purchasers should obtain the latest relevant information on Siderion products before placing orders. Siderion products are sold pursuant to Siderion's terms and conditions of sale in place at the time of order acknowledgement.

Purchasers are solely responsible for the choice, selection, and use of Siderion products and Siderion assumes no liability for application assistance or the design of Purchasers' products.

No license, express or implied, to any intellectual property right is granted by Siderion herein.

Resale of Siderion products with provisions different from the information set forth herein shall void any warranty granted by Siderion for such product.

Information in this document supersedes and replaces information previously supplied in any prior versions of this document.

2026 Siderion – All rights reserved

